

9101 Interior Mortise Latch Trim Options

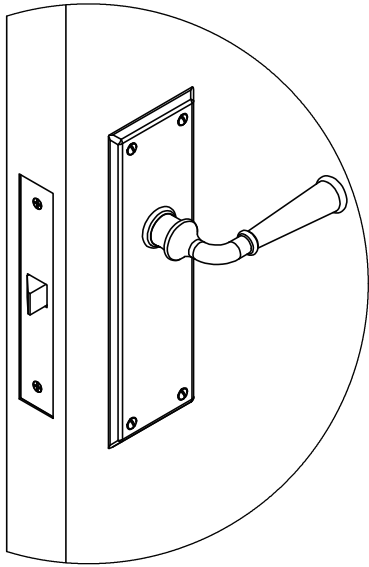

9101 Interior Mortise Lock
Shown with Abington Trim & 8821 Lever
(Lever High Configuration)

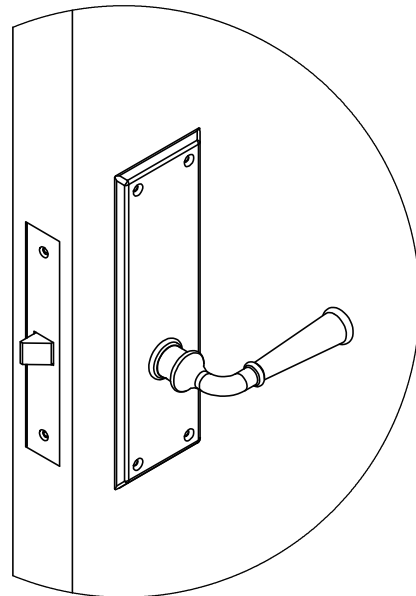

9101 Interior Mortise Lock
Shown with Abington Trim & 8821 Lever
(Lever Low Configuration)

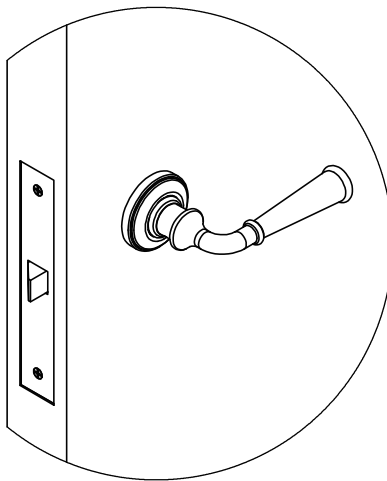

9101 Interior Mortise Lock
Shown with Non-Suited Section Trim & 8821 Lever
(Lever High Configuration)

THE INFORMATION CONTAINED IN THIS DRAWING IS THE SOLE PROPERTY OF ERIC MORRIS & COMPANY. ANY REPRODUCTION IN PART OR AS A WHOLE WITHOUT THE WRITTEN PERMISSION OF ERIC MORRIS & COMPANY IS STRICTLY PROHIBITED.

TITLE:

DO NOT SCALE DRAWING

SCALE:1:1

SHEET 1 OF 1



Phone: +1-856-997-0222
 Fax: +1-856-294-5116
 Email: info@ericmorrisandco.com
 Web: <http://www.ericmorrisandco.com>
 Address: ERIC MORRIS & COMPANY
 7249-A Browning Road
 Pennsauken, NJ 08109

DOOR PREP FOR 9101 INTERIOR MORTISE LOCK (IML) PASSAGE (Shown in Lever/Knob High Configuration)

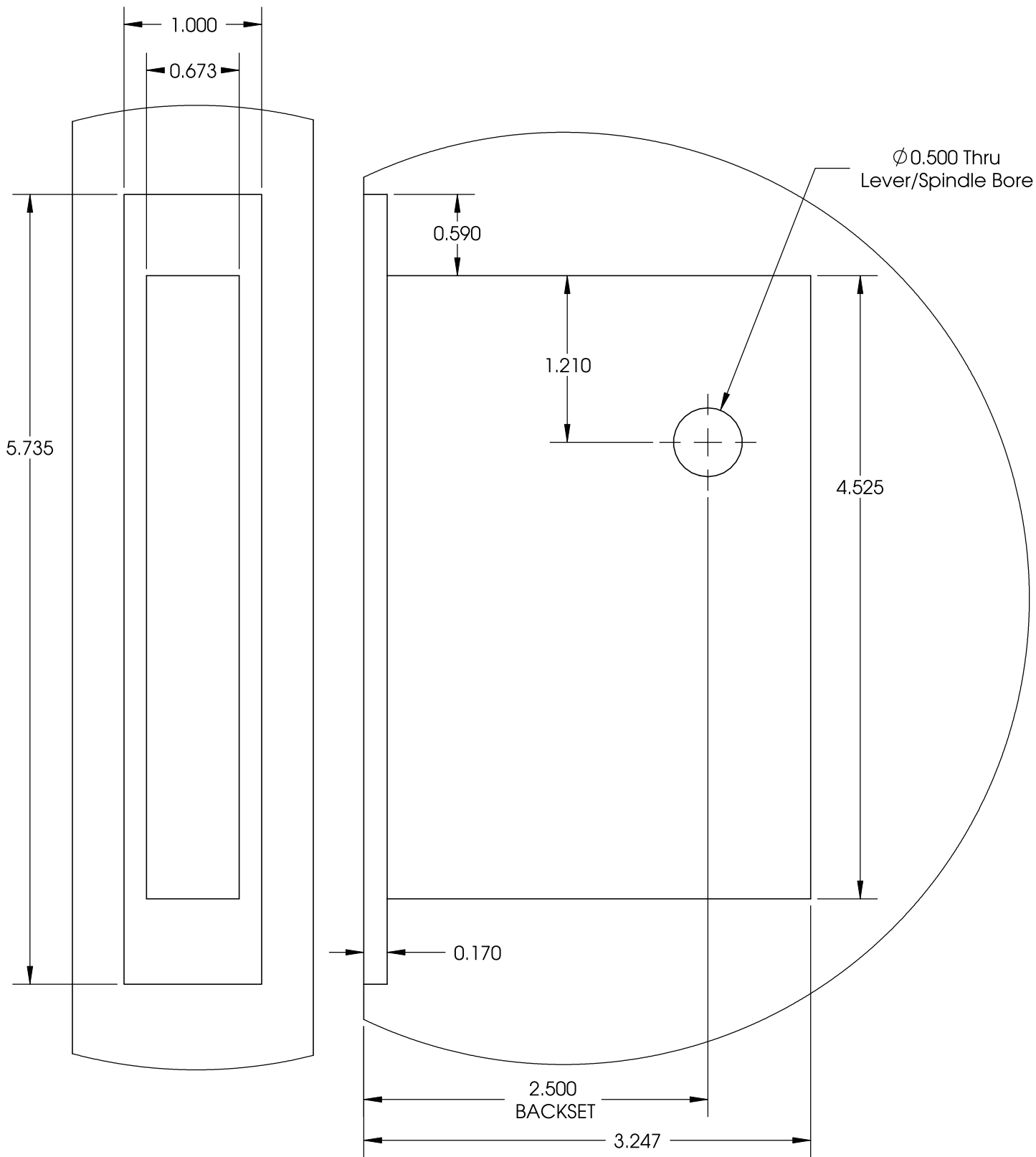

THE INFORMATION CONTAINED IN THIS DRAWING IS THE SOLE PROPERTY OF ERIC MORRIS & COMPANY. ANY REPRODUCTION IN PART OR AS A WHOLE WITHOUT THE WRITTEN PERMISSION OF ERIC MORRIS & COMPANY IS STRICTLY PROHIBITED.

TITLE:

DO NOT SCALE DRAWING

SCALE:1:1

SHEET 1 OF 1



Phone: +1-856-997-0222
 Fax: +1-856-294-5116
 Email: info@ericmorrisandco.com
 Web: <http://www.ericmorrisandco.com>
 Address: ERIC MORRIS & COMPANY
 7249-A Browning Road
 Pennsauken, NJ 08109

DOOR PREP FOR 9101 INTERIOR MORTISE LOCK (IML) PASSAGE (Shown in Lever/Knob Low Configuration)

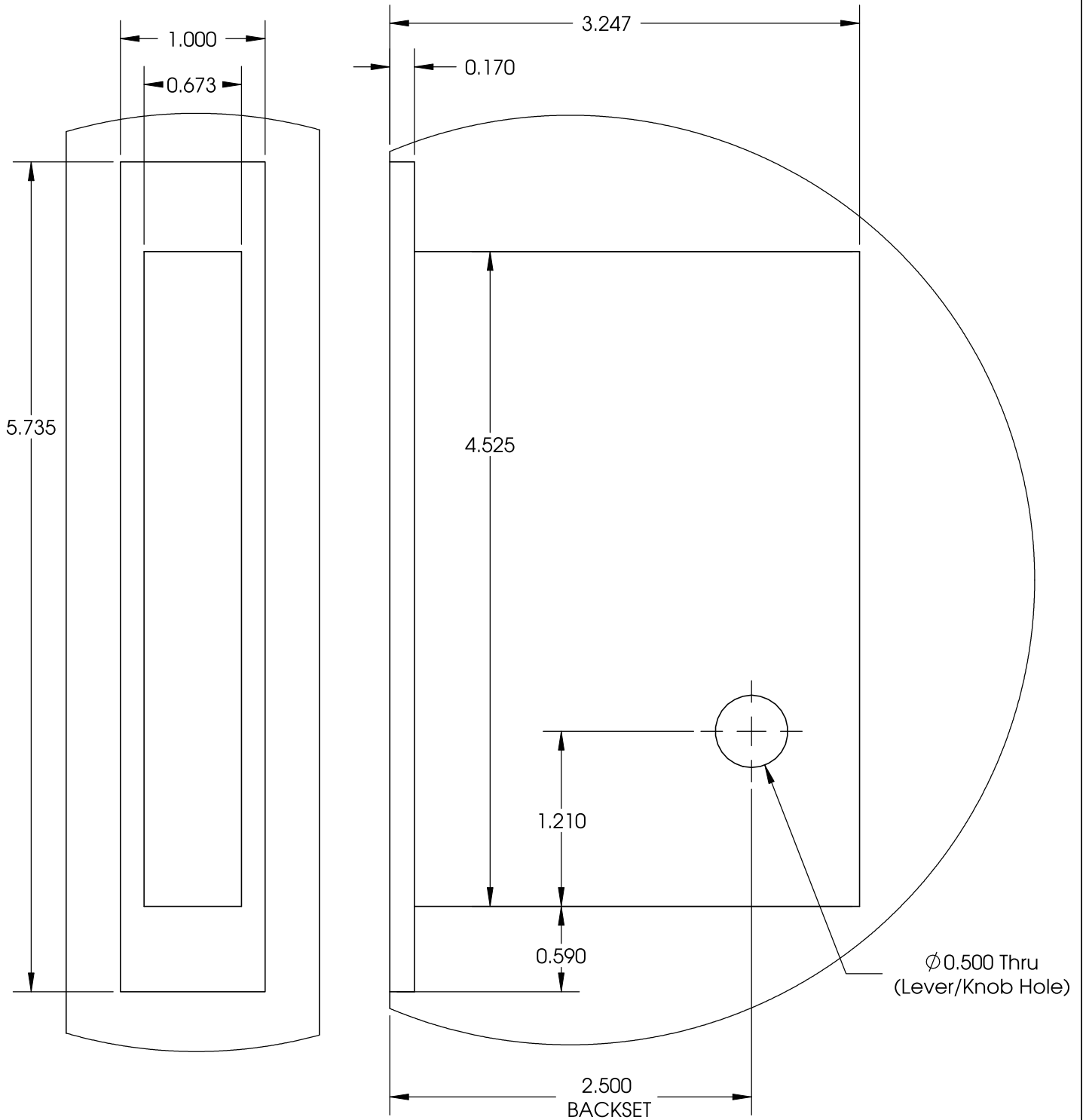

THE INFORMATION CONTAINED IN THIS DRAWING IS THE SOLE PROPERTY OF ERIC MORRIS & COMPANY. ANY REPRODUCTION IN PART OR AS A WHOLE WITHOUT THE WRITTEN PERMISSION OF ERIC MORRIS & COMPANY IS STRICTLY PROHIBITED.

TITLE:

DO NOT SCALE DRAWING

SCALE:1:1

SHEET 1 OF 1



Phone: +1-856-997-0222
 Fax: +1-856-294-5116
 Email: info@ericmorrisandco.com
 Web: <http://www.ericmorrisandco.com>
 Address: ERIC MORRIS & COMPANY
 7249-A Browning Road
 Pennsauken, NJ 08109

9101 IML INSTALLATION INSTRUCTIONS

- 1) Prep door as shown on first pages using typical door prep guide (lever/knob can be either high (shown) or low).
- 2) Install lock into the prepared door cut-out using the two (2) # 10 x 1" sheet metal screws provided as shown below.

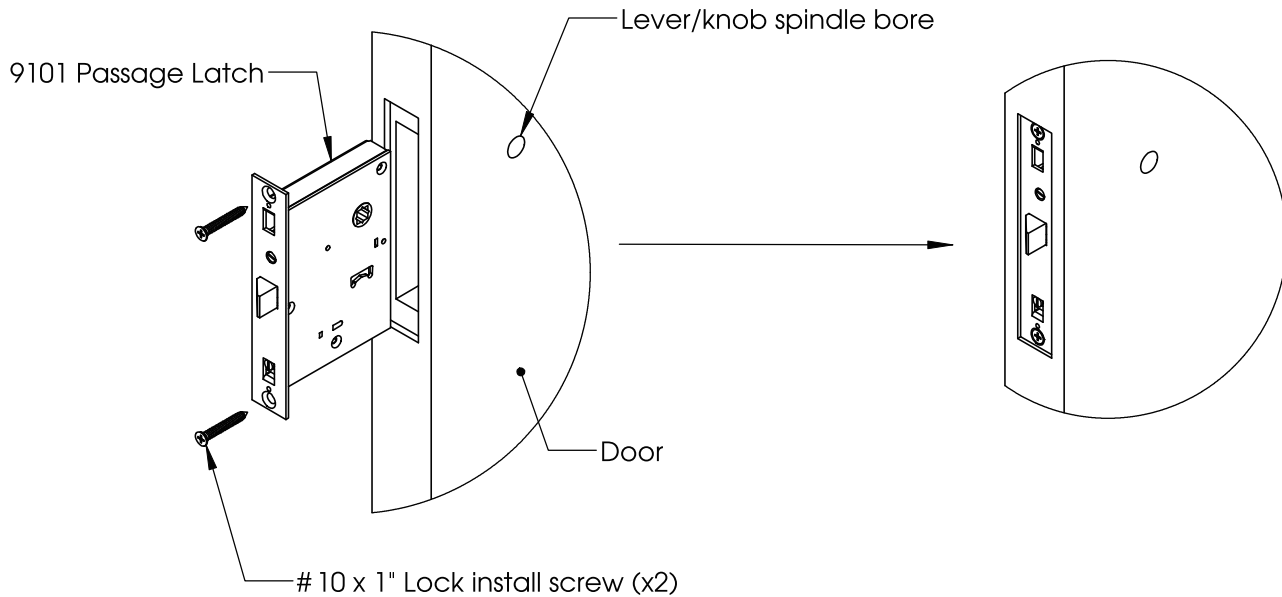

- 3) Pass the 9999 Alignment tool through both escutcheons (shown here) or rose mounts. Align both vertically and longitudinally and then attach the interior escutcheon plate (84100 Abington Escutcheon shown here) using the four (4) # 6 x 5/8" slotted wood screws provided, as shown below.

Note: Rosettes may be used in place of escutcheons.

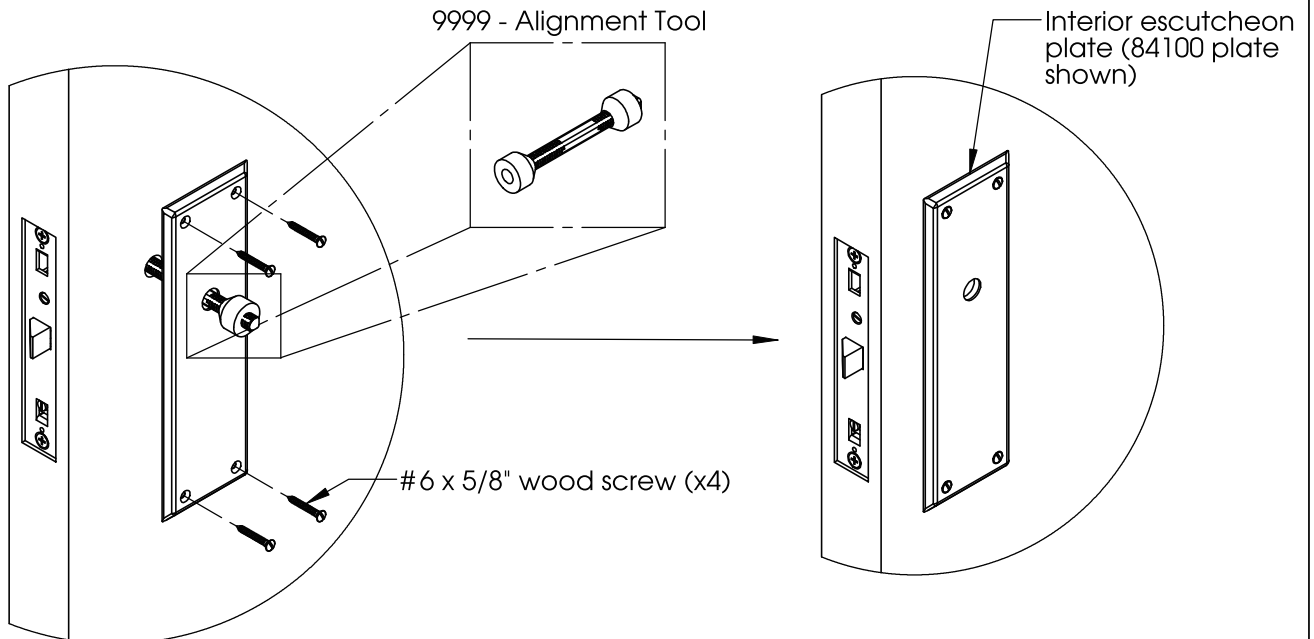

THE INFORMATION CONTAINED IN THIS DRAWING IS THE SOLE PROPERTY OF ERIC MORRIS & COMPANY. ANY REPRODUCTION IN PART OR AS A WHOLE WITHOUT THE WRITTEN PERMISSION OF ERIC MORRIS & COMPANY IS STRICTLY PROHIBITED.

TITLE:

DO NOT SCALE DRAWING

SCALE:1:1

SHEET 1 OF 1



Phone: +1-856-997-0222
Fax: +1-856-294-5116
Email: info@ericmorrisandco.com
Web: <http://www.ericmorrisandco.com>
Address: ERIC MORRIS & COMPANY
7249-A Browning Road
Pennsauken, NJ 08109

4) Attach exterior escutcheon (or rosette) to the exterior side of the door using the four (4) #6 x 5/8" wood screws provided as shown below.

NOTE: Again, as shown, the use of the 9999 alignment tool is recommended.

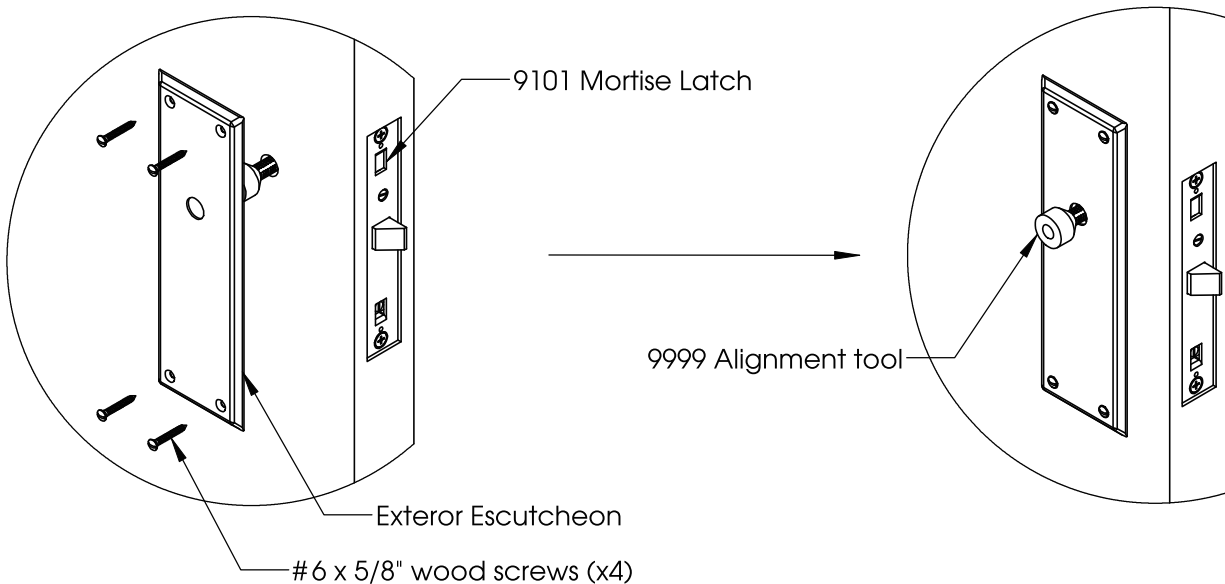

5) Insert square spindle into the exterior lever (or knob) until the spindle bottoms out as shown below. Secure the spindle into the lever using the two set screws (tighten the set screw that goes into the spindle cut-out first to prevent crushing the spindle).

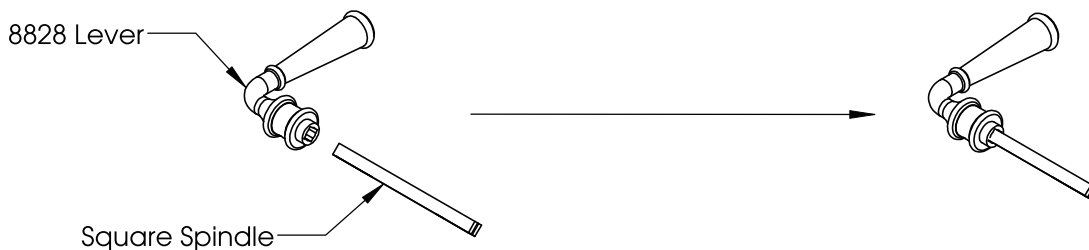

6) Insert lever/spindle assembly through the exterior side of the door until the lever is seated right up against the escutcheon or rose. The spindle should project through the door to the interior.

NOTE: Ensure to align the spindle in the 7mm diamond broach shown below (indicated with dashed lines).

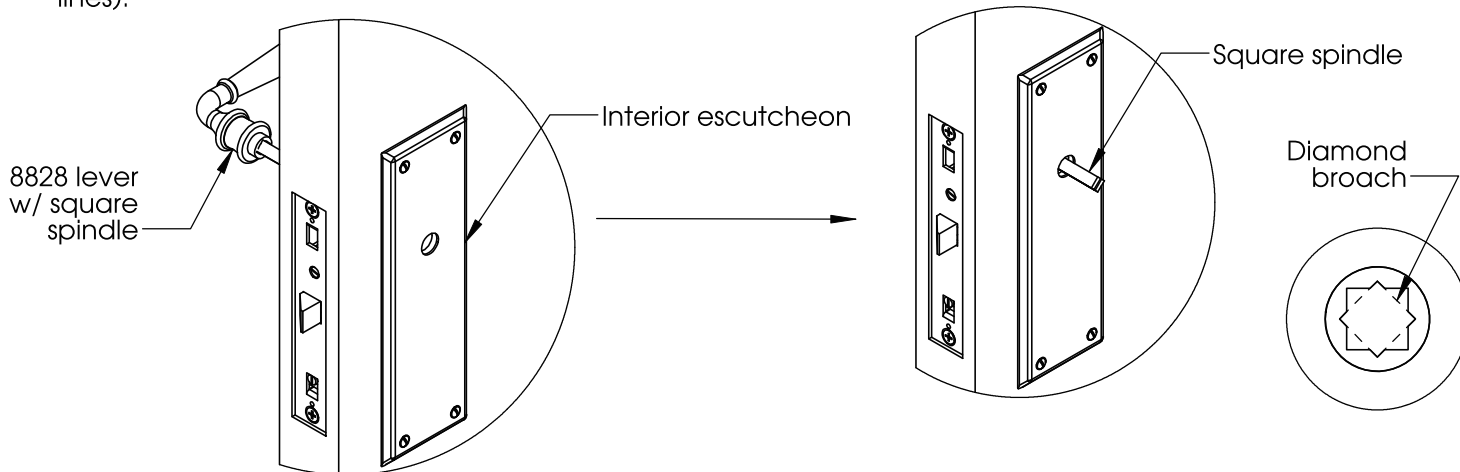

THE INFORMATION CONTAINED IN THIS DRAWING IS THE SOLE PROPERTY OF ERIC MORRIS & COMPANY. ANY REPRODUCTION IN PART OR AS A WHOLE WITHOUT THE WRITTEN PERMISSION OF ERIC MORRIS & COMPANY IS STRICTLY PROHIBITED.

TITLE:

DO NOT SCALE DRAWING

SCALE:1:1

SHEET 1 OF 1



Phone: +1-856-997-0222
 Fax: +1-856-294-5116
 Email: info@ericmorrisandco.com
 Web: <http://www.ericmorrisandco.com>
 Address: ERIC MORRIS & COMPANY
 7249-A Browning Road
 Pennsauken, NJ 08109

7) Attach the interior lever to the door by sliding the lever (or knob) onto the spindle until it rests against the escutcheon or rosette as shown below (the spindle may have to be cut to allow the lever or knob to seat properly). Secure the lever to the spindle by tightening the two set screws (be sure to tighten the set screw in the spindle cut out first to prevent crushing the spindle).

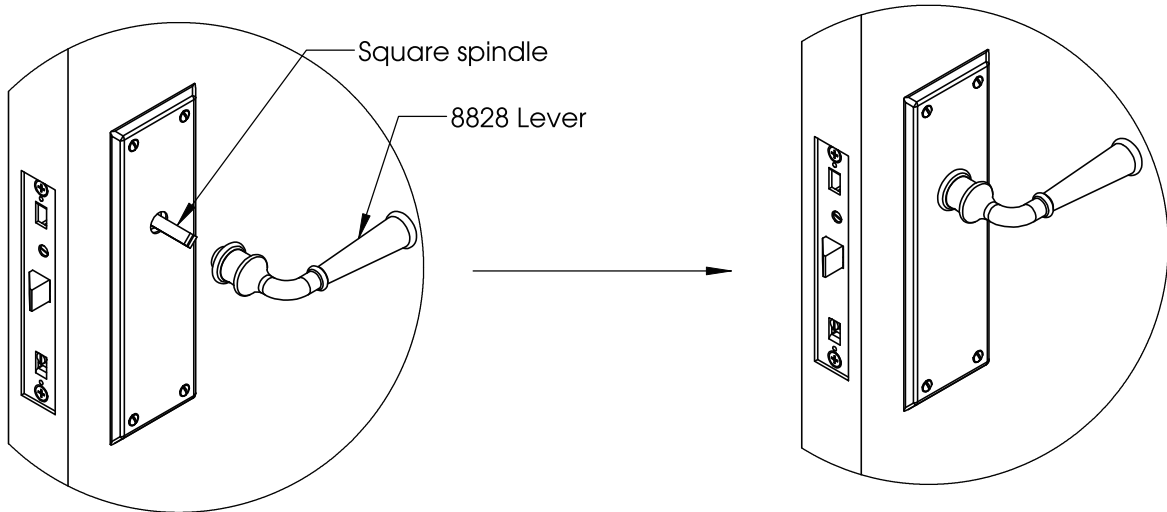

NOTE: Prior to installing the finished face plate on the lock, adjust the hub angle and tension using the tools shown below. Loosen lock nut with the spanner wrench. Insert allen wrench through the spanner wrench and adjust knob/lever alignment. Once desired alignment is reached, re-tighten the lock nut with the spanner wrench.

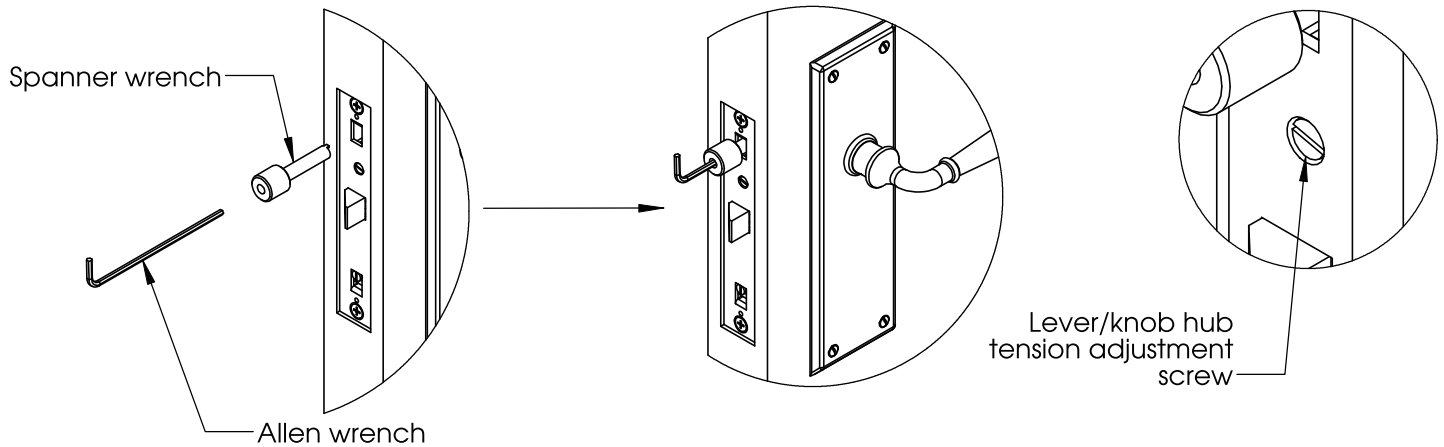

NOTE 2: When the lever/knob tension screw is turned clockwise, it will increase the tension, when turned counter-clockwise it will lessen the tension

9) After lock has been adjusted as per above note, attach finished face plate using the two (2) #4 x 1/4" machine screws as shown below.

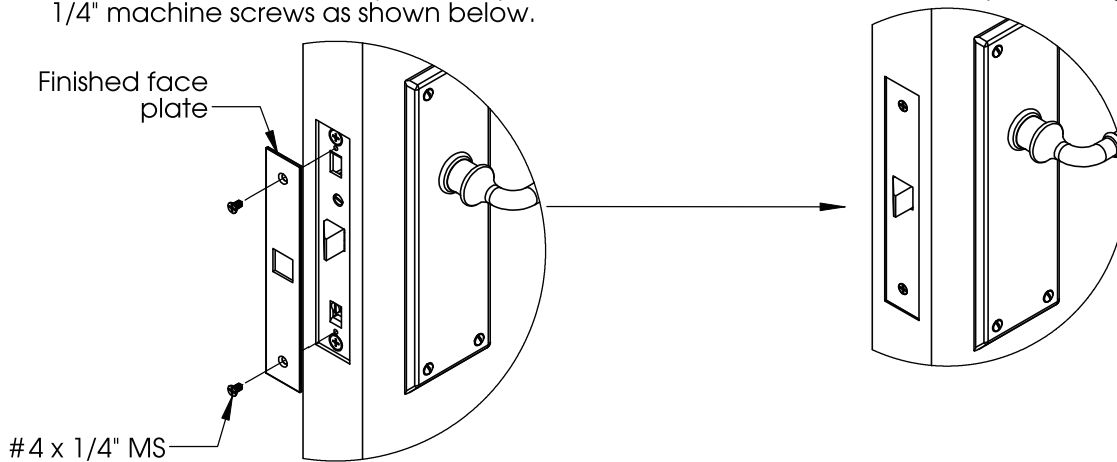

THE INFORMATION CONTAINED IN THIS DRAWING IS THE SOLE PROPERTY OF ERIC MORRIS & COMPANY. ANY REPRODUCTION IN PART OR AS A WHOLE WITHOUT THE WRITTEN PERMISSION OF ERIC MORRIS & COMPANY IS STRICTLY PROHIBITED.

TITLE:

DO NOT SCALE DRAWING

SCALE:1:1

SHEET 1 OF 1



Phone: +1-856-997-0222
 Fax: +1-856-294-5116
 Email: info@ericmorrisandco.com
 Web: <http://www.ericmorrisandco.com>
 Address: ERIC MORRIS & COMPANY
 7249-A Browning Road
 Pennsauken, NJ 08109

IML Passage Strike and Layout Details

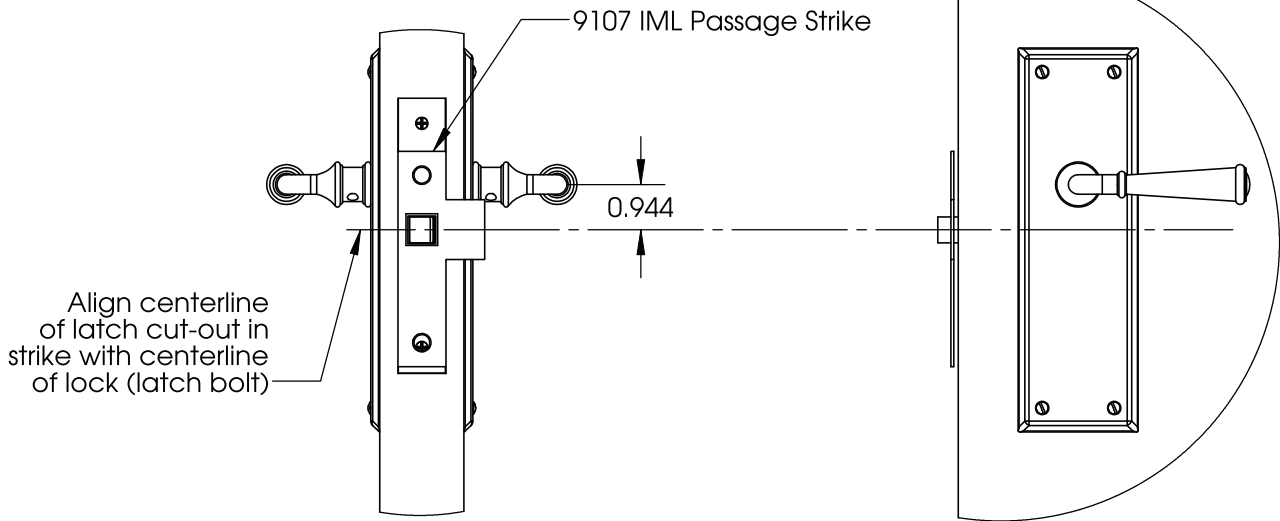
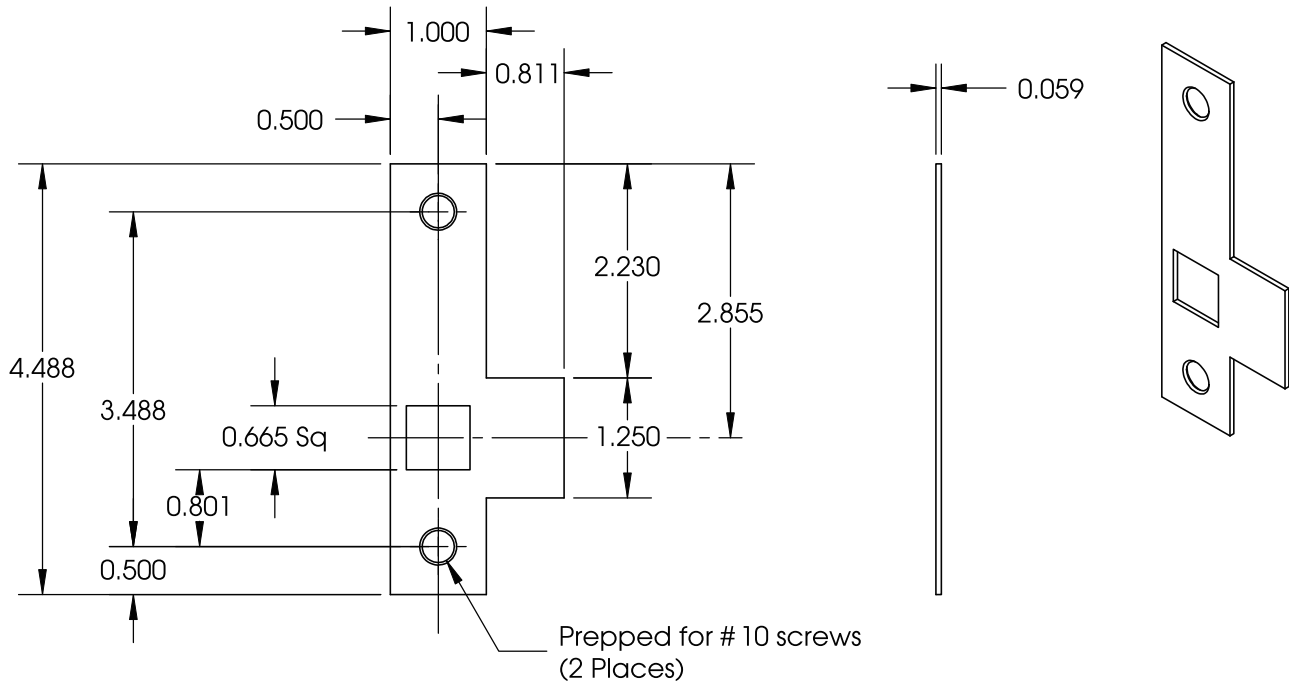

THE INFORMATION CONTAINED IN THIS DRAWING IS THE SOLE PROPERTY OF ERIC MORRIS & COMPANY. ANY REPRODUCTION IN PART OR AS A WHOLE WITHOUT THE WRITTEN PERMISSION OF ERIC MORRIS & COMPANY IS STRICTLY PROHIBITED.

TITLE:

DO NOT SCALE DRAWING

SCALE:1:1

SHEET 1 OF 1



Phone: +1-856-997-0222
 Fax: +1-856-294-5116
 Email: info@ericmorrisandco.com
 Web: <http://www.ericmorrisandco.com>
 Address: ERIC MORRIS & COMPANY
 7249-A Browning Road
 Pennsauken, NJ 08109